

Nexus[®] 1500+

Next Generation Power Quality Meter for Critical Energy Circuits



Advanced Metering and Communication

- Constant Calibration™ Architecture Provides Highly Stable Readings, as the Meter Self-calibrates Every 10 Seconds
- Critical Metering Needs are Met by 0.06% Accuracy in Energy Metrology
- Color Touchscreen Programmable Display Enhances the Meter's Functionality
- 6 Available Communication Ports, Including Dual Ethernet Ports
- Ethernet Ports Offer Secure, Configurable Port Services Control
- Supported COM Protocols Include Modbus, DNP3, IEC 61850, GOOSE Messaging, and SNMP

Superior Recording and Power Quality Analysis

- Class A IEC 61000-4-30 Edition 3 Power Quality Measurement
- Class A IEC 61000-4-15 Flicker Measurement
- Class A IEC 61000-4-7 Harmonics Measurement
- Supports Customized EN 50160 Power Quality Reporting
- Offers up to 4 GB of Memory for Storage
- Offers 50 MHz Transient Capture Speed
- The Perfect Meter for Co-generation and Independent Power Providers
- Supports Substation Automation, Grid Monitoring, and Distribution Substation Reliability Measurements

Introduction

The Nexus® 1500+ meter is designed to be a primary and testable revenue meter that additionally provides advanced power quality analysis functions. It records every aspect of electrical power, including power quality and transients, and gives you access to this information both in real time and through reports on the quality of the electrical circuit in compliance with the IEC 61000-4-30 Class A Edition 3 and EN 50160 international standards. In this way, the Nexus® 1500+ meter provides you with a comprehensive picture of your circuits' power usage and reliability.

The Nexus® 1500+ meter's capabilities insure that essential data is captured and stored, so that critical information about important electrical circuits is not lost. Designed with superior processing power that lets it measure energy usage precisely, large amounts of memory for recording events, and advanced power quality reporting compliance, the Nexus® 1500+ meter is the clear choice for your applications where critical metering is an absolute necessity, be it for power utility, industrial, or other critical metering usage.

Highly Accurate Energy Metrology

The Nexus® 1500+ meter incorporates one of the most advanced metrologies available for measuring energy. Providing highly accurate measurements exceeding the ANSI C12.20 (0.2 Class) standard and the IEC 62053-22 (0.2S Class) standard, the 1500+ provides an Energy Class accuracy of 0.06%, with typical shipping accuracies of 0.02%. Additionally, the meter has a highly accurate front panel test pulse that lets you test on one pulse at low pulse weight, which you can use to quickly determine accuracy. The meter also features a new precision real time clock that offers accuracy of 3.5 ppm, or less than 10 seconds per month drift.

Typical Accuracy over Current Range

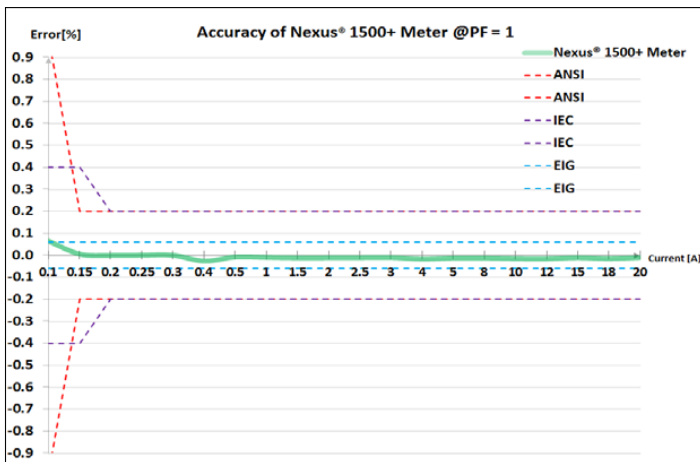

Typical 0.02% Accuracy over Full Range

Note that typical accuracy is 0.02%; however, the meter specification should be consulted for accuracy details.

New Constant Calibration™ Architecture Increases the Stability of Measurement Accuracy

The Nexus® 1500+ meter improves on existing Nexus® architecture by providing one of the best auto-calibration methods available. Earlier Nexus® models relied on AccuMeasure™ technology that auto-calibrated the meter every 12 hours or 5 degree temperature change. Constant Calibration™ architecture improves significantly on this, by providing considerably faster, ongoing auto-calibration.

With Constant Calibration™ architecture, the meter utilizes a separate calibration channel to calibrate the incoming signal in real time every 10 seconds, thereby insuring that the meter experiences minimal drift in accuracy over time and temperature. With this auto-calibrating circuit, right out of the box the Nexus® 1500+ meter will stabilize its readings within 10 seconds. This means you no longer have to wait for the meter to stabilize in temperature to achieve optimal accuracy. With Constant Calibration™ architecture, the meter will hold its accuracy throughout its operation range. Once the meter is tested, it will maintain the precise accuracy even if the operating conditions are less than ideal.

Typical Meter Accuracy Charts

Drift over Temperature

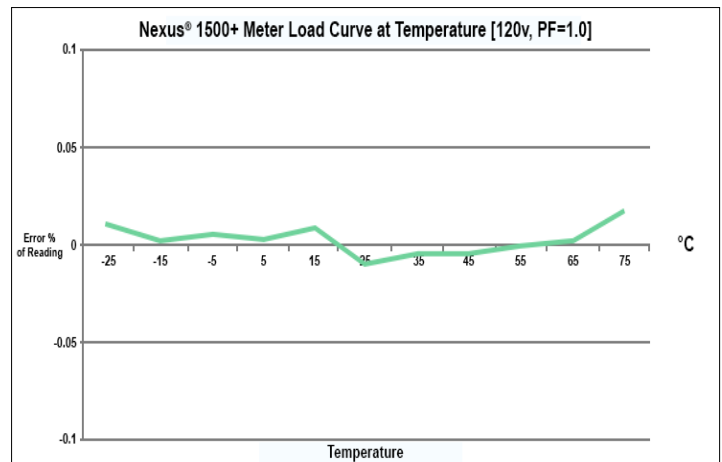

Meter Maintains Accuracy over Changing Temperature

Advanced Revenue Meter for Primary Loads

The Nexus® 1500+ unit is a primary revenue meter designed to be used for any important applications. In addition to highly accurate energy measurement, the meter features:

- Full 4 quadrant metering
- Energy load profiling: log virtually unlimited historical trending
- Time of Use perpetual calendar that supports multiple tariffs
- Transformer and Line Loss compensation: for both iron and copper and total substation losses
- CT and PT compensation: correct for errors in current and voltage transformers
- Coincidental readings: e.g., PF or VARs at time of Peak Demand, to identify number of capacitors needed, peak inefficiencies, etc.
- Load aggregation/universal metering: pulse inputs can be used to aggregate or accumulate different loads; utility products such as gas and water can also be accumulated

System Events Logging

The unit provides extensive usage information for detection of unauthorized access. The unit records:

- Resets
- Programming changes.
- Password access changes
- Time changes
- Power up/down
- Change of Firmware

Test Mode and Energy Presets

The Nexus® 1500+ meter offers a Test Mode for testing meter accuracy. Test Mode allows the meter to be tested for watt-hour and VAR-hour accuracy without affecting the stored readings. Using Test Mode, users can verify the meter's readings over the lifespan of an installed meter without having to reset energy or disturb the load profiling and demand recording.

The Energy Preset feature allows a user to program the energy accumulator values upon exiting Test Mode. This lets the user compensate for accumulations missed during testing time, or easily swap a new meter for a meter being replaced.

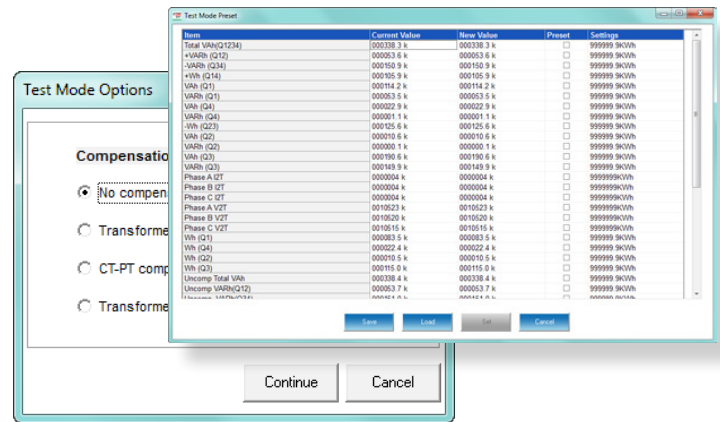

Perpetual Time of Use for Complex Metering

The Nexus® 1500+ meter uses a perpetual Time of Use (TOU) calendar that only needs to be set up once. The TOU implementation allows the user to set up multiple tariffs to meet any contractual obligations. It also allows the user to customize any energy parameter for TOU. The 16 available TOU registers can be configured not only for TOU built-in energy readings, but also for any stored data from pulses or RTU Master readings that might need TOU functionality.

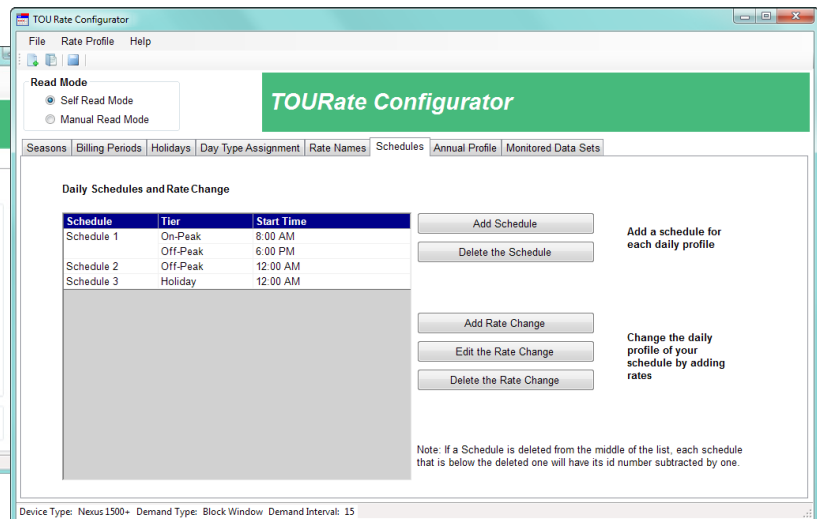
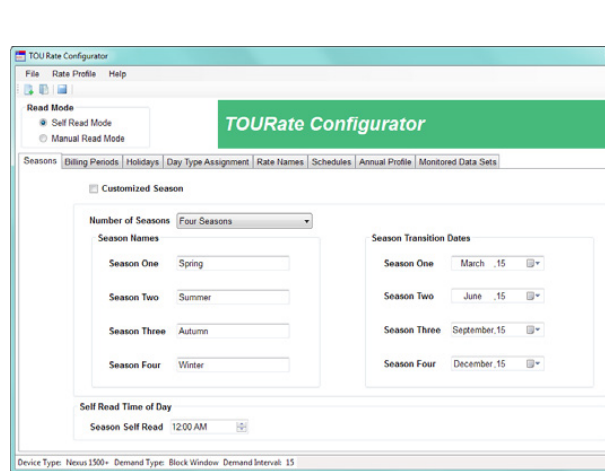

Class A Power Quality Recorder

EIG's Nexus® 1500+ meter is one of the industry's premier fault and voltage disturbance recorders. This instrument captures and stores a comprehensive picture of the history of voltage reliability and power quality events, for detailed and extensive forensic engineering analysis. The Nexus® 1500+ meter offers a multitude of power quality functionality that helps the user identify power quality problems, including harmonics, sags, swells and transients. Power quality features include:

IEC 61000-4-30 Class A Ed. 3 Power Quality Meter:

The Nexus® 1500+ meter is a comprehensive Class A power quality recorder. Designed specifically to meet the rigorous IEC 61000-4-30 Class A Edition 3 standard, it measures and analyzes power quality precisely. All reporting is available via the EN 50160 reporting format, which provides a weekly report of power quality indices system-wide. Additionally, the report can be fully customized to meet the required application or jurisdictional needs.

- IEC 61000-4-30 Reporting: Class A Reporting – supports the most stringent international power quality standards; the Nexus® 1500+ meter offers full reporting of power quality conditions using the IEC 61000-4-30 Class A methodology.
- Automatic generation of EN 50160 reports and EN 50160 report customization to support different jurisdictional requirements.

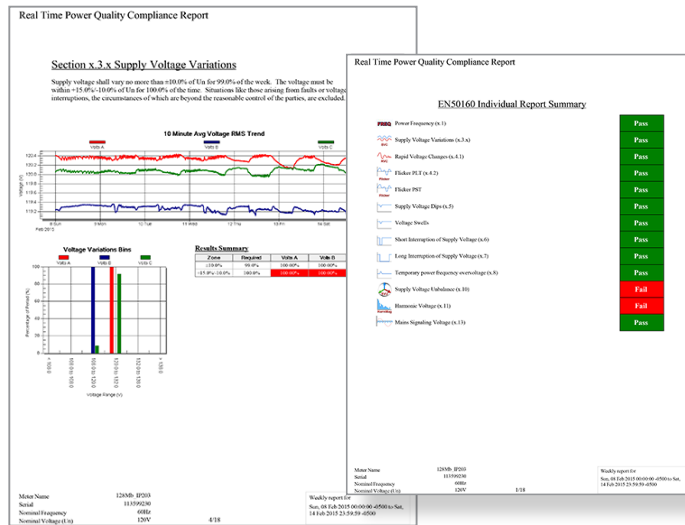

Easy-to-Understand Reports Displaying PQ Compliance

IEC 61000-4-15 Class A Flicker Meter:

- Flicker compliant with the IEC 61000-4-15 Class A standard.
- Flicker measurement operates on both 220 volt/50 Hz and 120 volt/60 Hz throughout standard test points.

IEC 61000-4-7 Class A Harmonics and Interharmonics Analysis:

- View harmonic magnitudes to the 511th order for each voltage and current channel.
- Harmonic magnitudes and phase angles in real time are resolved to the 127th order.
- Obtain THD, TDD, and K-Factor.
- Conduct power quality analysis at the high end of the harmonic magnitude spectrum.

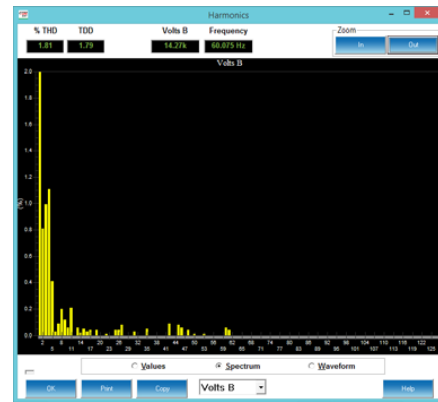

Phasor Analysis:

The monitor reads a phase angle analysis between the voltage and current channels, allowing you to analyze efficiency and system integrity.

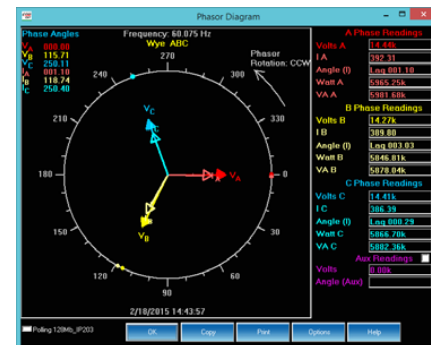

High-speed Voltage Reliability Measurements:

The Nexus® 1500+ meter provides industry leading voltage measurement.

- Real time single cycle RMS measurements
- Customizable high-speed readings – can be set from 2 to 20 cycles RMS

Set Limit Control:

The Nexus® 1500+ power monitor provides the user with programmable setpoints. This feature allows a user to configure the meter to be used as a control device for many applications, such as:

- Capacitor control
- Load shedding
- Automatic transfer schemes
- Transformer monitoring & control
- Redundant protection (not designed for primary over-current protection)
- Many other control functions

Alarm Notification:

- The Nexus® 1500+ meter lets you set multiple programmable limits for any measured value, as well as those set up in a Boolean logic tree, and limits set up in the IEC 61850 protocol implementation. Users can be notified of alarm conditions via email.

16 Bit Waveform and Fault Recorder:

- Record up to 1024 samples per cycle; capture a transient at over 800,000 samples per cycle or at 50 MHz sampling speed.
- Voltage and current recording has pre and post-event analysis.
- Fault recording offers 8 times full scale capture capability.
- 16 bit A/D converter provides precise waveform resolution.
- Both hardware and software triggers are available.

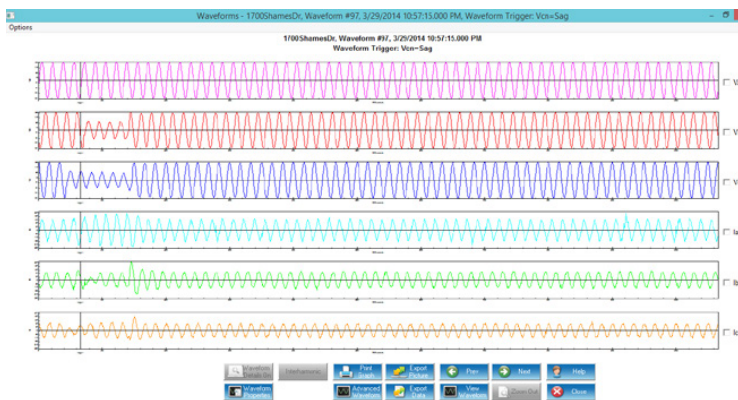

Record and Analyze Waveform Fault and Transient Data

High-speed Status Input Triggers:

- Waveforms are recorded at time of status change.
- Input change and waveform recording are time-stamped to a 100 micro second resolution.
- Inputs and waveforms can be displayed together to time breakers and relays.

Subcycle 50 MHz Transient Recorder (V3 Option):

Transients often cause intermittent, expensive periods of downtime. The subcycle transient recorder allows you to:

- Record subcycle transients at 50 MHz resolution.
- Monitor switching noise from capacitors, static transfer switches, SCRs, and other devices that negatively impact power quality.

This feature is essential for critical applications such as hospitals, wafer-fabs plants, data centers and other highly power quality sensitive applications.

Independent ITIC/CBEMA Log Plotting:

- Quickly view total surges, sags, and average duration in the independent ITIC/CBEMA log.
- SEMI F47 graphing is available for power quality compliance in the semi-conductor industry.

Compatible Waveform Formats

Using Communicator EXT™ software, the meter will provide all waveform data via COMTRADE and PQDIF compatible formats. This allows the waveform PQ and fault records to be read by most third-party waveform analysis software programs.

- COMTRADE (common format for transient data exchange) is defined by IEEE Std C37.111.
- PQDIF (power quality data interchange format) is defined by IEEE Std 1159.3-2003.

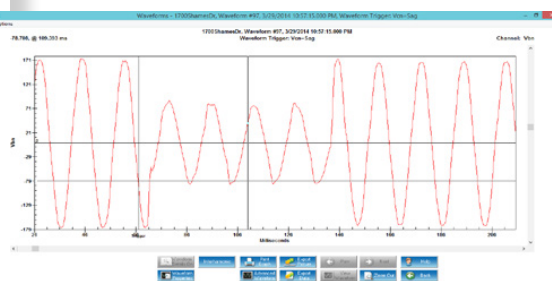

Multiport Communication

The Nexus® 1500+ meter offers up to 6 simultaneous communication ports and multiple protocols to meet almost every need.

Hardware Features:

- 2 optional RS485 ports speaking Modbus and/or DNP 3.0
- USB front panel port
- ANSI optical front panel port
- 2 separately addressable Ethernet ports
- Optional Fiber or RJ45 media on one Ethernet port

Ethernet Communication Port Capabilities:

- 2 Ethernet ports provide multiple simultaneous communication
- Each port has separate MAC address and IP address
- Supports Modbus TCP/IP, DNP3 and IEC 61850
- GOOSE messaging protocol supported for IEC 61850
- Up to 32 Modbus TCP/IP sockets per Ethernet port
- Highly secure port control to disable unneeded services and ports
- Email Function - SMTP email to client on alarm
- Precise Time Synchronization - SNTP Time Sync protocol
- File Transfer Protocol - High-speed file data transfer

Industry-Leading DNP3 Level 2 Plus - Complies with DNP Level 1 and Level 2 Certification Requirements:

Requirements:

- Up to 136 measurements (64 Binary Inputs, 8 Binary Counters, 64 Analog Inputs) can be mapped to DNP static points.
- Up to 16 relays and 8 resets can be controlled through DNP.
- Report-by-exception processing (DNP Events) deadbands with unsolicited response for serial communication is supported.
- 250 events in four event types (Binary Input Change, Frozen Counter, Counter Change, and Analog Change) are available.

SNMP Protocol:

- SNMP protocol V1 and V2c supported
- 40+ measurements supported
- Traps for limits, input change, and power quality
- Cold Start trap and Authentication Failure supported
- Perfect for data centers and other managed device networks

8 Built-in Digital High-speed Status Inputs:

- Inputs automatically sense whether the circuit is externally wetted.
- If externally wetted, input up to 150 V DC is accepted.
- If internally wetted, the meter supplies the necessary voltage for the control application.

VAUX Input:

- Neutral to ground or aux voltage readings
- Synchronizing schemes, for example, obtaining the frequency, magnitude, and phase angle on both sides of a switch or between generator and bus voltage

Secure Communication

The Nexus® 1500+ meter offers 9 levels of password security to protect the meter from unauthorized use. Each level can be configured to enable specific capabilities, so that a Utility can control access to functions according to the type of user. For example, one user level is able to create and change TOU calendars, while a different user level is able to read TOU data, but not change anything.

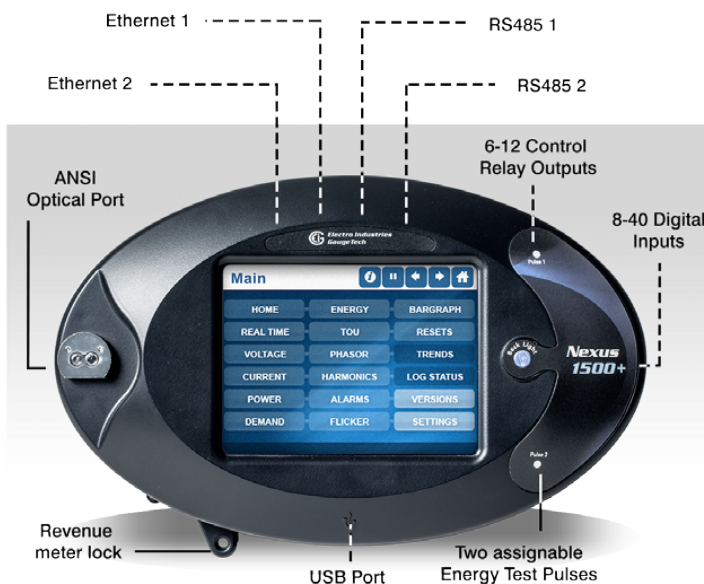

Highly Capable Communication Options

Substation Automation

V-Switch™ key levels V2 and above offer an embedded IEC 61850 Protocol Server for seamless integration with substation automation applications. Features of the Nexus® 1500+ meter's IEC 61850 implementation include:

- The IEC 61850 Protocol Server allows up to 6 simultaneous MMS clients.
- Either Ethernet port can be configured for IEC 61850 (only one port at a time can run IEC 61850).
- GOOSE publisher/subscriber functionality is supported.
- Buffered and unbuffered reports are supported for the following triggers: general meter interrogation, for example, the report is generated in response to a query; meter integrity, for example, the report is generated according to a programmed interval; and data change, for example, the report is generated due to a change in the contents of a dataset.
- File transfer is supported.
- Embedded Web Protocol Server support is available for IEC 61850 CID file uploading, IEC 61850 Protocol Server status and for displaying incoming and outgoing GOOSE messages.
- Multiple Logical Nodes, which map flicker, harmonics, digital inputs/outputs, limit state, voltage, current, energy and other data, are supported.
- Waveform capture can be triggered by status input data inside GOOSE messages. The user can program up to 16 status inputs that will trigger a waveform capture when the information is received via a GOOSE message. The status inputs include digital inputs, limit states, and any other status input supported by the meter.

V-Switch™ Key Technology

The Nexus® 1500+ meter is equipped with V-Switch™ key upgrade technology that lets you upgrade meter functionality even after installation. This means you can purchase what you need now and then upgrade whenever you need the additional features. Following are the available V-Switch™ keys.

Feature	V1	V2	V3
Basic Measurements	*	*	*
Memory	512 MB	1 GB	4 GB
Sampling Speed	512	1024	Up to 800,000
50 MHz Transients			*
EN61000-4-30 Class A Edition 3	*	*	*
IEC 61850 Server		*	*
IEC 61850 GOOSE		*	*

Unique GOOSE Cross Trigger:

- Fault-based cross trigger of waveform based on GOOSE message.
- Provides system-wide distribution fault analysis on an event.
- Timing better than 200 microseconds is typical.
- Many different circuits can be viewed after an event occurred.

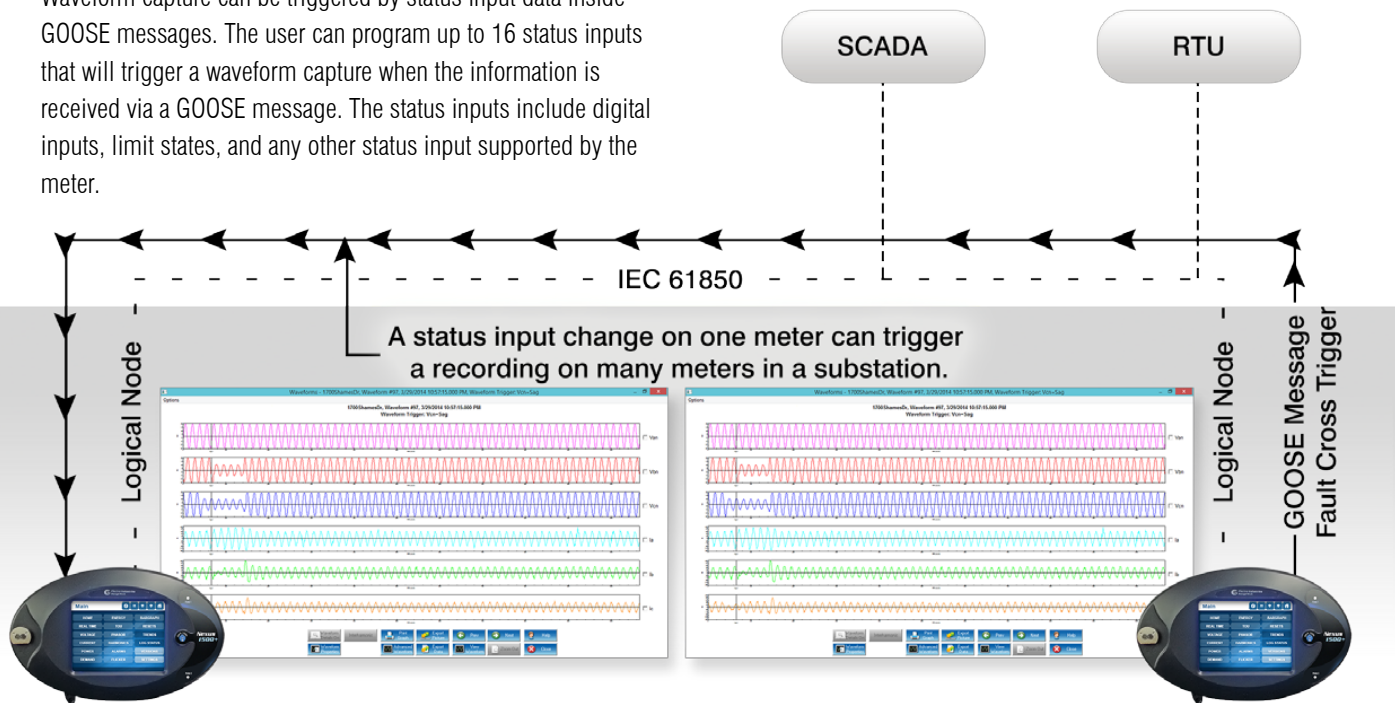

The Meter of Choice for Critical Energy Measurement



Power Generation



Grid Automation

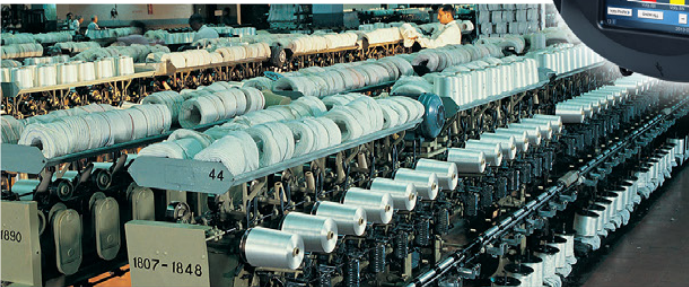

Industrial



Commercial/Data Center



Utility 1

Utility 2

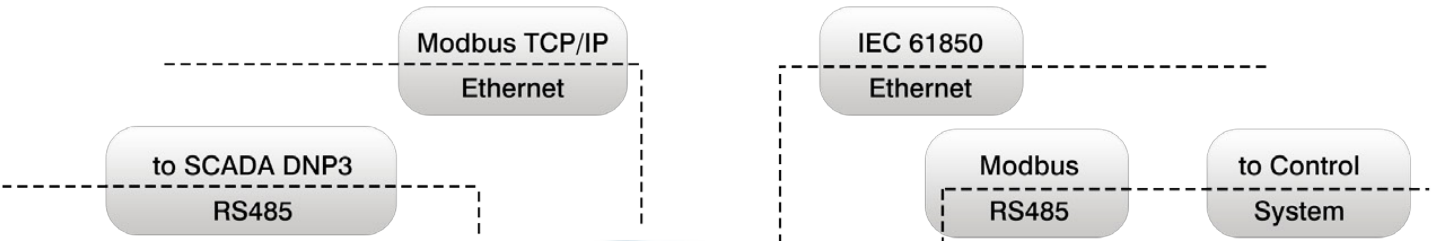

Designed for Use between Two Utility Tie Points
or for Critical SCADA Data

Internal I/O

Pulse Outputs:

485P: Dual RS485/Pulse Output Card

- 4 KYZ pulses - Solid State
- Pulse width: 5 ms
- Two RS485 ports

Relay Outputs:

6R01: 6 Relay Output Card

- 5 A, 250 V AC/30 V DC
- Form C (Latching)

Digital Input Status:

16D11: 16 Status Inputs Card

- Used for alarm detect or pulse accumulation
- Up to 150 V DC wetted or non-wetted (24 V DC internally provided)

Note: The Nexus® 1500+ meter provides one I/O slot for the 485P (Slot 1), and two I/O slots for the 6R01 and 16D11 (Slots 3 and 4).

External I/O

Analog Outputs:

- 1mAON4/1mAON8: 4 or 8 Analog Outputs, 0-1 mA, self-powered, scalable, bidirectional
- 20mAON4/20mAON8: 4 or 8 Analog Outputs, 4-20 mA, self-powered, scalable
- Wiring: Common Mode
- Accuracy: 0.1% of Full Scale
- Calibration: Self-calibrating
- Scaling: Programmable
- Ordering: Up to 4 Analog Output modules

Analog Inputs:

- 8AI1: 8 Analog Inputs, 0 ± 1 mA

- 8AI2: 8 Analog Inputs, 4-20 mA
- 8AI3: 8 Analog Inputs, 0 ± 5 V DC
- 8AI4: 8 Analog Inputs, 0 ± 20 V DC
- Wiring: Common Mode
- Accuracy: 0.25% of Full Scale
- Scaling: Programmable
- Ordering: Up to 4 Analog Input modules

Digital Dry Contact Relay Outputs:

- 4R01: 4 Relay Outputs, 5 A, 250 V AC/30 V DC, Form-C Latching
- Ordering: 1 module in addition to internal modules

Digital Solid State Pulse Outputs:

- 4P01: 4 Solid State Pulse Outputs, Form A or C KYZ pulses
- Maximum Pulse Speed: 20 pulses per second
- Ordering: Up to 4 Digital Solid State Output modules

I/O Module Accessories (Required):

- PSIO: Power supply required when using an external I/O module. The Nexus® 1500+ meter does not have internal power for external I/O modules.
- MBIO: Mounting bracket for external I/O modules. Must be ordered with external I/O module.

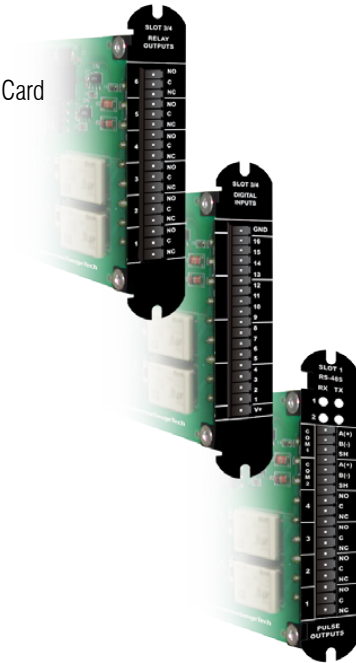

Expandable External I/O Modules

Vibrant LCD Touch Screen Display

The Nexus® 1500+ meter features an LCD color display with touch screen capability. The display uses bright TFT glass with a high temperature and long life LED backlight. LED is superior to CCFL solutions due to better temperature and half-life specifications. Screen displays include:

- Real-time viewing (voltage, current, power, demand)
- Accumulated energy and time of use readings
- Flicker readings
- Alarms
- Phasor Analysis
- Harmonic spectrum analysis and waveforms
- Real time trending
- Log status
- Configuration settings
- Multi-language support
- Digital status inputs



Vivid Color Display

Wiring Diagrams

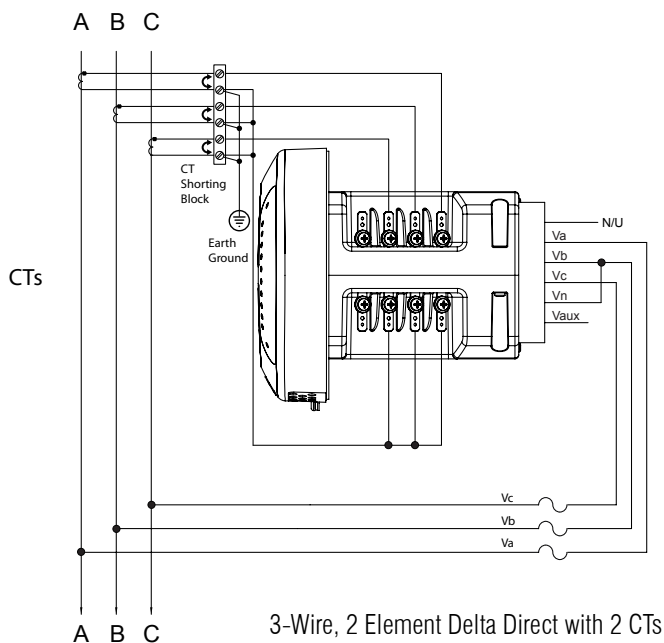
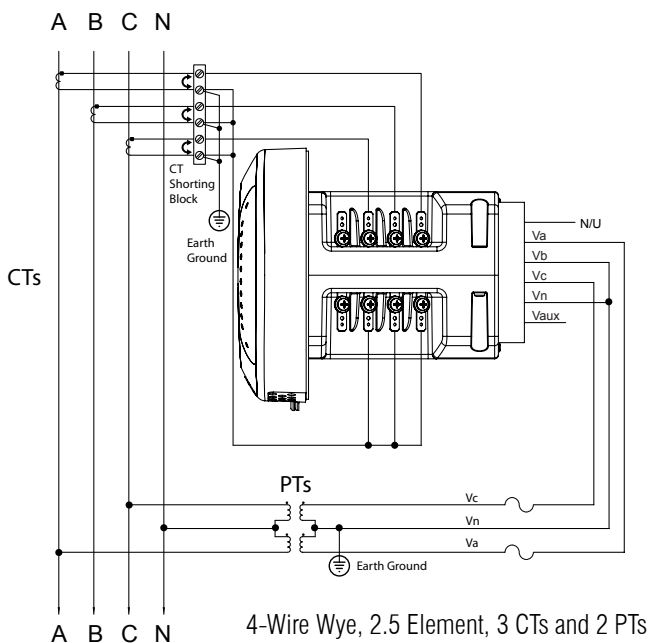
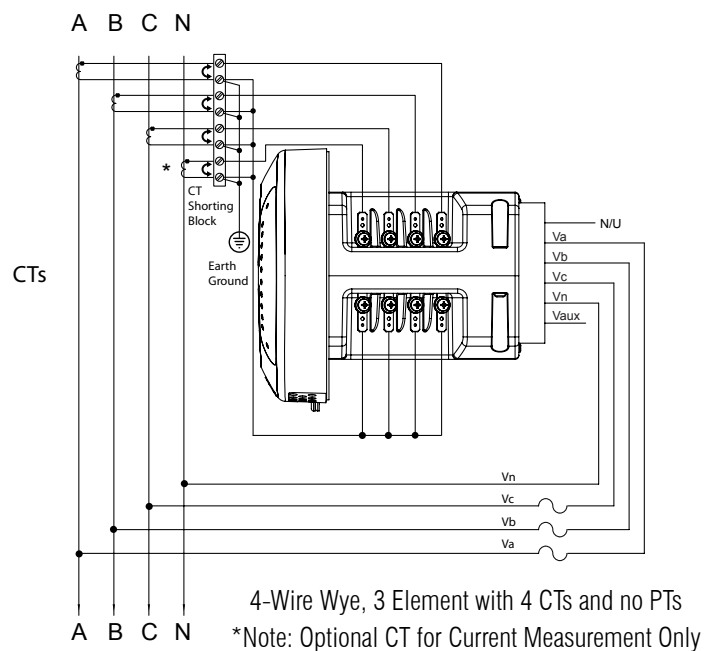
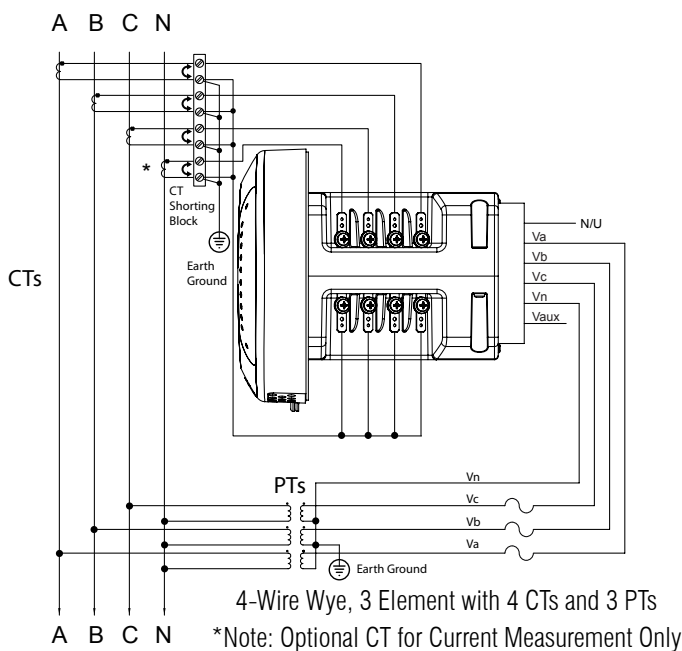

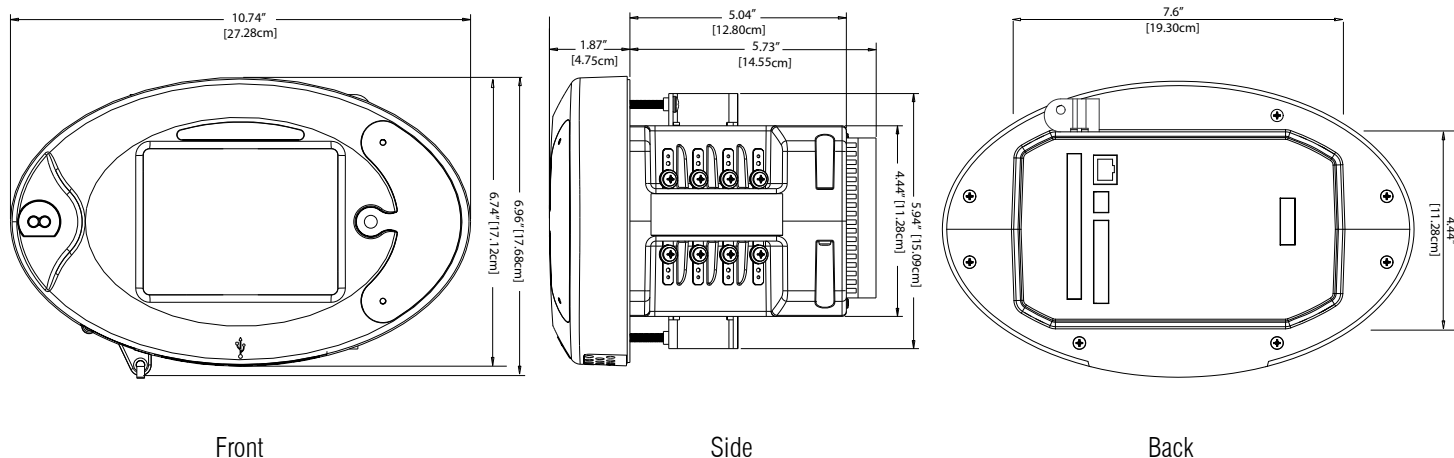

Specifications

Voltage Input Range:

- (5-347) V AC, Line to Neutral
- (10-600) V AC, Line to Line

Voltage Input Withstand Capability:

- Voltage Inputs isolated to 2500 V AC

Current Input Range:

- Programmable to any CT ratio
- Class 2: Nominal 1 A, with 2 times over range
- Class 2: fault current recording to ± 16 A peak
- Class 20: Nominal 5 A, with 4 times over range
- Class 20: fault current recording to ± 80 A peak

Current Input Withstand Capability (at 23°C):

- 100 A for 10 seconds
- 300 A for 3 seconds
- 500 A for 1 second

Burden:

- Voltage Inputs: 0.072 VA/phase max at 600 volts, 0.003 VA/phase max at 120 volts
- Current Inputs: 0.008 VA per phase max at 20 A

Isolation:

- All inputs to outputs are isolated to 2500 V AC

Temperature Rating:

- Operating temperature: (-20 to +70) °C
- Storage temperature: (-30 to +80) °C
- Humidity: Up to 95% RH non-condensing

Sensing Method:

- Up to 1024 samples per cycle (programmable)
- 16 Bit A/D resolution – multiple converters
- Constant Calibration™ technology
- True RMS
- Transient at 50 million samples per second

Accuracy Rating:

- Energy measurement accuracy at 0.06%

- Full accuracy specifications available in Nexus® 1500+ meter User Manual
- Time clock: 3.5 ppm for (-40 to +85) °C - less than 10 seconds drift per month on crystal sync; 2.0 ppm typical from (0 to +40) °C - less than 6 seconds per month drift

Update Time:

- 1 Second - Revenue accurate readings
- 1 Cycle - Faster updated readings
- Customizable high-speed readings - from 2 to 20 cycles RMS

Control Power Requirements:

- D2 Option: (100-240) V AC @50/60 Hz or (100-240) V DC
- 115AC Option: (100-240) V AC @50/60 Hz
- D Option: (18-60) V DC (24-48 V DC Systems)
- Burden: 25 VA Max

Frequency Range:

- (45-69.9) Hz

Communication:

- Programmable parity and stop bits
- Communication protocols: Modbus TCP/IP, ASCII/RTU; DNP3; IEC 61850 (V2 and above), SNMP
- ANSI optical port
- USB 1.1/2.0 Virtual COM port
- RJ45 Ethernet port 10/100BaseT
- Optional 2nd Ethernet port - RJ45 or Fiber Optic
- 2 RS485 ports (optional)

Shipping:

- Total shipping weight: approx. 6.5 lbs (2.9 kgs)
- Shipping container dimensions: 16" x 15.5" x 11.5" (40.64 cm x 39.37 cm x 29.21 cm)

Compliance:

- ANSI C12.20 (0.2 Class) and IEC 62053-22 (0.2S Class) Accuracy
- ANSI C12.1 (Code for Electricity Metering)

- ANSI C62.41 (Burst)
- ANSI/IEEE C37.90.1 – Surge Withstand
- FCC Part 15, Subpart B, Class A
- IEC 61000-4-2 – ESD
- IEC 61000-4-3 – Radiated Immunity
- IEC 61000-4-4 – Fast Transient
- IEC 61000-4-5 – Surge Immunity
- IEC 61000-4-6 – Conducted Immunity
- IEC 61000-4-7 – Harmonics
- IEC 61000-4-15 – Flicker Meter
- IEC 61000-4-30 – Class A Ed. 3
- IEC 62052-11 - General Requirements
- IEC/CISPR 14-1 - Continuous EM Disturbance
- CE Marked
- UL and cUL Listed

External I/O Modules

- 1mAON4: 4 Analog Outputs, 0 \pm 1 mA
- 1mAON8: 8 Analog Outputs, 0 \pm 1 mA
- 20mAON4: 4 Analog Outputs, 4-20 mA
- 20mAON8: 8 Analog Outputs, 4-20 mA
- 8AI1: 8 Analog Inputs, 0 \pm 1 mA
- 8AI2: 8 Analog Inputs, 4-20 mA
- 8AI3: 8 Analog Inputs, 0 \pm 5 VDC
- 8AI4: 8 Analog Inputs, 0 \pm 10 VDC
- 4RO1: 4 Relay Outputs
- 4PO1: 4 Solid State Pulse Outputs
- PSIO: Power Supply for I/O modules (must be ordered with external I/O module)
- MBIO: I/O mounting bracket (must be ordered with external I/O module)

Note: Please see product User Manual for comprehensive specifications.

To order a Nexus® 1500+ meter:

- Fill out the options you want in the order chart shown below: list accessories separately.
- Specify Communicator EXT™ 4.0 software.
- EIG can also provide current and potential transformers.
- Email or fax order information and quantity to the email address or fax number listed below, or call the phone number listed below to place your order.

Ordering Information

	Nexus® Base Meter	Control Power	Frequency Range	Current Class	Virtual Switch	Communication Expansion/Slot 1	I/O Slot 2	I/O Slot 3	I/O Slot 4
Option Numbers:	-	-	-	-	-	-	-	-	-
Example:	Nexus 1500+	D2	60	20	V2	485P	NTRJ	6RO1	6RO1
	Nexus® 1500+ Meter	115AC (100-240) V AC @50/60 Hz	60 60 Hz	20 20 A	V1 Standard Nexus® 1500+ Meter 512 MB memory / 512 s/c	X No Option	X No Option	X No Option	X No Option
		D2 Universal (100-240) V AC @50/60 Hz or (100-240) V DC	50 50 Hz	2 2 A	V2 V1 + 1 GB memory / 1024 s/c IEC 61850	485P 2 RS485 and 4 Pulse Outputs	NTRJ Second RJ45 Network Card	6RO1 6 Relay Outputs	6RO1 6 Relay Outputs
		D (18-60) V DC			V3 V2 + 4 GB memory / 50 MHz Transient Recording		NTFO Second Fiber Network Card (ST terminated)	16DI1 16 Status Inputs	16DI1 16 Status Inputs

Accessory Options

Software

COMEXT4P1Y Communicator EXT™ 4.0 Software for Windows
Single-Computer License (One Site)

I/O Modules

1mAON4	4 Analog Outputs, 0±1 mA	*PSIO	Power Supply for External I/O Modules
1mAON8	8 Analog Outputs, 0±1 mA		
20mAON4	4 Analog Outputs, 4-20 mA		
20mAON8	8 Analog Outputs, 4-20 mA	*MBIO	I/O Mounting Bracket
8AI1	8 Analog Inputs, 0±1 mA		
8AI2	8 Analog Inputs, 4-20 mA		
8AI3	8 Analog Inputs, 0±5 VDC		
8AI4	8 Analog Inputs, 0±10 VDC		
4RO1	4 Relay Outputs		
4PO1	4 Solid State Pulse Outputs		

* Must be ordered with an external I/O module.

About Electro Industries: Electro Industries/GaugeTech is one of the oldest and largest manufacturers of microprocessor-based digital power meters in the United States. EIG's success is attributable to our willingness to support our users with on-staff technical expertise. Contact us and we will assist you in solving your complex metering applications.

Nexus® 1500+ web page:

http://electroind.com/product-info/nexus-1500_plus-next-generation-power-quality-revenue-meter/



1800 Shames Drive, Westbury, NY 11590 **1-877-EIMETER** (1-877-346-3837)
Tel: 516-334-0870 **Fax:** 516-338-4741 **Email:** sales@electroind.com
www.electroind.com