

Nexus® 1252

For Easy Viewing of Voltage,
Current and Power

19-inch Rack Mount

Meter Assembly



- Ideal for Substation 19" Rack Mount Control Panel Applications
- Incorporates Nine Simultaneous Lines of Display
- Provides Clear and Easy Viewing of Data with No Scrolling
- Built-in Testing Switch
- Designed Specifically for Nexus® 1252 Meters
- Front Panel Download Port

Electro Industries/GaugeTech introduces a new rack assembly that offers the Nexus® 1252 advanced performance power meter and power quality recorder together with nine LED lines of display in one mountable unit.

The 19" rack assembly also features a built-in test switch and a front download port. These displays allow for 3 phases of voltage, 3 phases of amps, Watt/VAR, and PF displayed simultaneously with no need to scroll.

The three LED displays consist of the following:

- P40N+: Master LED display providing either multifunction measurement or use as a Volts 3 line master unit.
- P41N+: LED Amps display - Slave 3 line display
- P43N+: LED Power display - Slave 3 line display



Front RS232 Port

Wiring

The displays are connected to the meter through their back serial ports. The serial port connection from the displays is connected to Port 3 of the Nexus® 1252 meter. There is a serial port connection from Port 1 of the Nexus® 1252 meter to the front of the mounting unit.

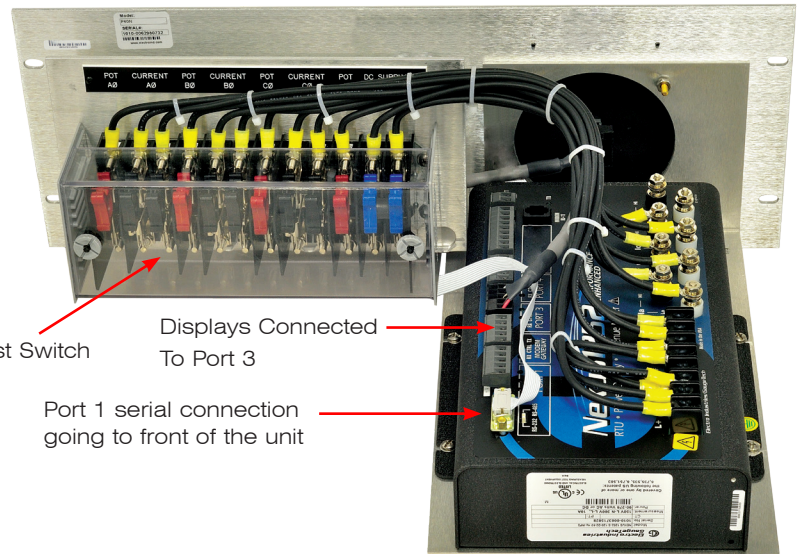

Test Switch

Displays Connected To Port 3

Port 1 serial connection going to front of the unit

Ordering Information (To order, please use this guide)

	Model	Memory	Input Voltage	Control Power	Nominal Frequency	V-Switch™ Pack	Internal Expansion Port Options	Revenue Seal	Style Option
Option Numbers:									
Example:	1252	A	120	D	60	V1	X	X	4RU3DSP
	1252	A Advanced	120 (0-150) V L-N (0-300) V L-L	D (18-60) V DC Power Supply	60 Hz	V1 Standard Nexus® 1252 Meter	X No Expansion Port	X (No Seal)	4RU3DSP 3 Displays
			G 300 V L-N 600 V L-L	D2 (90-276) V AC/DC Power Supply	50 Hz	V2 Advanced	INP200 10/100BaseT Rapid Response™ Ethernet	ICR Revenue Seal	
					400 Hz				

Accessory Options

DIMENSIONS

LENGTH	19 inches (48.26 cm)
HEIGHT	7 inches (17.78 cm)
DEPTH	14 inches (35.56 cm)

WEIGHT

16 lbs (with packaging)

BOX PACKAGING DIMENSIONS

LENGTH	24 inches (60.96 cm)
HEIGHT	18 inches (45.72 cm)
DEPTH	18 inches (45.72 cm)



1800 Shames Drive, Westbury, NY 11590

1- 877-EIMETER (1-877-346-3837) P 516-334-0870 F 516-338-4741

Email: sales@electroind.com www.electroind.com